



QUANTUM Series PD60L

Bandwidth Saving DVB-S2 L-band Modem



OVERVIEW

The low cost **QUANTUM Series PD60L** brings the *bandwidth saving* and *robustness* benefits of **DVB-S2** to traditional SCPC services such as IBS and Drop & Insert. In addition, **Paired Carrier** technology overlays transmit and receive carriers reducing satellite bandwidth by up to 50%. Paired Carrier™ technology is patented by Viasat Inc.

QUANTUM modems are fully backward compatible with Paradise Evolution modems when DVB-S2 and Paired Carrier are disabled.

SCPC features, DVB-S2 Space Segment

Modes of operation:

- ▶ DVB-S2 outbound with SCPC return, or SCPC outbound with DVB-S2 return.
- ▶ DVB-S2 outbound and return.
- ▶ SCPC outbound and return.
- ▶ SmartLink mode where Tx/Rx SCPC features are combined with DVB-S2 space segment savings. All traditional SCPC features are supported including IBS, IDR, ESC, Drop & Insert, AUPC, etc.

FEATURES

- ▶ Data rate options to 60Mbps, 37.5Msymbol/s maximum.
- ▶ All the standard features and options of the Evolution Series Modem including IBS, IDR, Drop & Insert, etc.
- ▶ DVB-S2 FEC and modulation support.
- ▶ Paired Carrier ready. Requires just an upgrade.
- ▶ Ethernet plus a further 3 x traffic interfaces supporting a wide range of terrestrial interfaces.
- ▶ Supports up to two Quad E1 cards allowing up to 8 x E1s to be multiplexed onto a single carrier
- ▶ Available in IF, L-band, and IF plus L-band.

Paired Carrier Operation

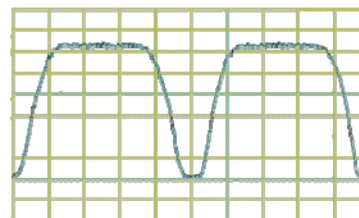

Paired Carrier Disabled

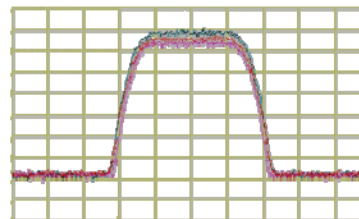

Paired Carrier Enabled
Can save 50% on space segment

Paradise Datacom LLC
328 Innovation Blvd.
State College, PA 16803 USA
Tel: 1 (814) 238-3450
Fax: 1 (814) 238-3829

www.paradisedata.com

Paradise Datacom Ltd.
1 Wheaton Road, Witham
Essex CM8 3UJ England
Tel: +44(0) 1376 515636
Fax: +44(0) 1376 533764

Common Main Specifications	
Parameter	QUANTUM Series Modem
Modulation Scheme	SCPC: BPSK, QPSK, OQPSK, 8PSK (Option), 16QAM (Option) DVB-S2 (Option): QPSK, 8PSK, 16QAM
L-band Frequency Range	950 - 1950MHz
L-band Frequency Resolution	100Hz
Traffic Interface - Electrical	Ethernet (10/100 BaseT) IP Traffic on RJ45 with link and traffic indicators. Electronically selectable with other interfaces fitted.
Traffic Interface - Options	RS422 including X.21 DCE and DTE emulation, V.35 and RS232 on EIA530 connector 25 pin female D-type (Option), EIA530 maximum 10Mbps, RS232 max 100kbps Serial LVDS 25 pin female D-type (Option) HSSI 50 pin HD SCSI-2 connector (Option) G.703 balanced on EIA530 G.703 unbalanced on BNC female 75Ω Quad E1 G.703 balanced on RJ45 IP Traffic card 10/100/1000 BaseT on RJ45 Eurocom D/1 on 25 pin male D-type includes: Eurocom D <16kbps to >2,048kbps AMI coded Eurocom C 256kbps, 512kbps, 1,024kbps and 2,048kbps HD/3 coded, plus Eurocom G 16kbps or 32kbps diphas coded MultiMux feature allows a mix of multiple G.703 interfaces plus IP and/or EIA530 traffic with a limit of 2,048kbps per MultiMux traffic port (4 x ports max)
User Traffic Data Rate	SCPC: 4.8kbps - 2,048kbps in base Modem DVB-S2 50kbps - 2,048kbps in base Modem, subject to minimum symbol rate of 100kbps Extension of base operation to 5Mbps (Option) Extension of 5Mbps to 10Mbps (Option) Extension of 10Mbps to 20Mbps (Option) Extensions are cumulative
User Traffic Data Rate Resolution	1bps
Note: The combination of FEC Rate, Modulation scheme and Satellite Overhead limits the Traffic Data Rate Range in all modes.	
User Data Rate Range - Closed Network	4.8kbps to 20Mbps no Satellite Overhead (with high Data Rate options)
User Data Rate Range - Minimum Overhead (Closed Network plus ESC)	As Closed Network above except limits inclusive of overhead of approximately 1.4 times the ESC baud rate. Resolution of 1bps. Supports ESC rate from 110 baud to >38.4kbaud.
User Data Rate Range - IBS/SMS Option	4.8kbps to 10 Mbps (6.7% Satellite Overhead added), Resolution of 1bps.
User Data Rate Range - IDR Option	4.8kbps to 10 Mbps (96k overhead added) Resolution of 8k (limitation of frame structure)
Audio Channels Option (P1348 emulation mode)	Used with IBS/SMS satellite framing and IDR Options to provide 2 x audio 32kbps ADPCM coded channels within a 64kbps IBS carrier, and 2 x audio 32kbps ADPCM coded channels plus 64kbps data within a 128kbps IBS carrier
Inner Forward Error Correction	Viterbi BPSK/QPSK/OQPSK - Rates 1/2, 3/4, 7/8, k=7 to IESS-308/309 Option: Sequential BPSK/QPSK/OQPSK - Rates 1/2, 3/4, 7/8 up to 2,048kbps maximum Option: TPC BPSK - Rates 5/16, 21/44, 0.493 (Paradise), 2/3, 3/4, 0.789 (Paradise), 7/8 (Paradise), Rate 7/8 de facto Option: TPC QPSK/OQPSK - Rates 5/16, 21/44, 0.493 (Paradise), 2/3, 3/4, 0.789 (Paradise), 7/8 (Paradise), Rate 7/8 de facto, Rate 0.93 (Paradise) Option: TPC 8PSK - Rates 3/4 de facto, 7/8 de facto, Rate 0.93 (Paradise) Option: TPC 16QAM - Rates 3/4 de facto, 7/8 de facto, Rate 0.93 (Paradise) Option: DVB-S2 LDPC Short FECFRAME=16.2k QPSK/ - Rates 1/2, 2/3, 3/4, 8PSK/8APSK - Rates 2/3, 3/4, 16QAM - Rate 3/4
Outer Forward Error Correction	Concatenated Interleaved Reed-Solomon Outer Codec to IESS308/310 with Custom Option offering variable code rate. Maximum traffic rate 10Mbps.
Scrambling - IBS/SMS Option	Synchronised to framing per IESS-309 up to 10 Mbps
Scrambling - IDR Option and Closed Network	With RS Coding: synchronised to RS overhead. Without RS Coding and Non-TPC FEC: V.35 self-synchronising No RS Coding with TPC FEC: 2 ¹² -1 up to 10 Mbps
Scrambling - SCPC Closed Network Plus ESC	32kbps or above: synchronised to ESC overhead. Less than 32kbps: as per closed network. V.35 Scrambler has CCITT, Intelsat, "FDC" and "Linkabit" modes up to 20Mbps (with high Data Rate options)
Scrambling - DVB-S2	As per ETSI EN 302307
L-band Connector type	N type female
L-band Impedance	50Ω
Return Loss	14dB typical
Internal Frequency Reference - Ageing	4E-8/yr
External Reference	Clocking Only: 1-10MHz in 1kHz steps. Clocking and RF Frequency: 10MHz, 0dBm±1dB

Modulator Specifications	
Parameter	QUANTUM Series Modem
Output Power Level	-5 to -30dBm Continuously Variable in 0.1dB steps
Output Level Stability	±0.5dB, 0°C to 40°C
Transmit Filtering Selectable	Intelsat IESS and DVB-S2 compliant α = 0.35 α = 0.25 α = 0.20
Occupied Bandwidth	1.2 x Symbol Rate 1.13 x SR 1.1 x SR
Recommended Channel Spacing	1.4 x Symbol Rate 1.27 x SR 1.2 x SR
Phase Accuracy	±2° maximum
Amplitude Accuracy	±0.2dB maximum
Carrier Suppression	>30dBc minimum
Output Phase Noise	As IESS-308, nominally 3dB better.
Output Frequency Stability	4E-8/yr
Harmonics	Better than -55dBc/4kHz in band
Spurious	Better than -55dBc/4kHz in band
Transmit On/Off Ratio	55dB minimum
External Transmit Inhibit	By external contact closure or by TTL signal applied to rear panel Alarms & AGC connector
Adaptive Signal Predistorter	Option: Use with 16QAM to relax HPA backoff by up to 1.6dB. Compensates for HPA non-linearities.

BER Performance - Guaranteed dB (Typical)						
SCPC mode	Rate 1/2	Rate 3/4	Rate 7/8	Rate 2/3	Rate 0.93	
Viterbi QPSK	1E-4	4.7 (4.4)	6.1 (5.8)	7.1 (6.8)		
	1E-8	7.2 (6.9)	8.8 (8.5)	9.5 (9.2)		
Sequential (64kbps)	1E-4	4.3 (4.0)	5.4 (5.1)	6.4 (6.1)		
	1E-8	6.4 (6.1)	7.3 (7.0)	8.6 (8.3)		
Sequential (2048kbps)	1E-4	5.6 (5.3)	6.1 (5.8)	6.9 (6.6)		
	1E-8	7.5 (7.2)	8.1 (7.8)	8.4 (8.1)		
Turbo (TPC) QPSK	1E-4	2.7 (2.4)	3.5 (3.2)	4.1 (3.8)		
	1E-6					6.3 (6.0)
Turbo (TPC) 8PSK	1E-4		5.6 (5.3)	6.8 (6.5)		
	1E-6					9.2 (8.9)
Turbo (TPC) 16QAM	1E-4		6.8 (6.3)	7.2 (6.8)		
	1E-6					10.0 (9.7)
8PSK/TCM	1E-3					6.3 (6.0)
	1E-8					10.4 (10.1)
8PSK/TCM + Reed-Solomon (all rates)	1E-4					6.1 (5.8)
	1E-10					7.3 (7.0)
DVB-S2 LDPC QPSK	1E-5	2.0 (1.7)	3.0 (2.6)	2.3 (2.0)		
	1E-9	2.3 (2.0)	3.3 (3.0)	2.7 (2.3)		
DVB-S2 LDPC 8PSK	1E-5		5.7 (5.3)			
	1E-9		6.0 (5.6)			5.7 (5.2)
DVB-S2 LDPC 8APSK	1E-5		5.2 (4.7)			4.6 (4.2)
	1E-9		5.7 (5.3)			5.0 (4.6)
DVB-S2 LDPC 16QAM	1E-5		6.8 (6.2)			
	1E-9		7.1 (6.8)			

Demodulator Specifications	
Parameter	QUANTUM Series Modem
Input Range Wanted Signal	Minimum level -130dBm + 10 log symbol rate Range 50dB above min, limited to -20dBm max
Maximum Composite Signal	30dB above level of desired input up to a maximum of -10dBm
Frequency Acquisition Range	Selectable from ±1kHz to ±32kHz up to 10 Msps (1kHz steps) ±10kHz to ±250kHz above 10 Msps (10kHz steps)
Acquisition Threshold	<5dB Es/No QPSK
Acquisition Time	At 9.6kbps, less than 1s at 6dB Es/No QPSK At 10 Mbps, less than 100ms at 6dB Es/No QPSK
Clock Tracking Range	±100ppm minimum
Receive Filtering Selectable	Intelsat IESS compliant α = 0.35, α = 0.25, α = 0.20
Performance Monitoring	Measured Eb/No (range 0-15dB, ±0.2dB). Measured Frequency Offset (100Hz resolution). Wanted signal level strength indicator centred on the middle of the Rx Input range.
AGC Output	Buffered direct AGC output for antenna tracking, etc.

Data Rate Specifications			
Modulation/FEC	FEC Rate de facto	Min Data Rate (kbps)	Max Data Rate (Mbps)
BPSK VIT / SEQ	1/2	4.8	18.7 / 2
BPSK VIT / SEQ	3/4	7.2	28.1 / 2
BPSK VIT / SEQ	7/8	8.4	32.6 / 2
BPSK VIT RS	1/2	4.3	16.5
BPSK VIT RS	3/4	6.4	24.7
BPSK VIT RS	7/8	7.5	28.8
O/QPSK VIT / SEQ	1/2	9.6	37.5 / 2
O/QPSK VIT / SEQ	3/4	14.4	56.2 / 2
O/QPSK VIT / SEQ	7/8	16.8	60 / 2
O/QPSK VIT RS	1/2	8.6	33
O/QPSK VIT RS	3/4	12.8	49.8
O/QPSK VIT RS	7/8	15	58.1
O/QPSK TPC	1/2	9.6	37.5
O/QPSK TPC	3/4	14.4	56.2
O/QPSK TPC	7/8	16.8	60
O/QPSK TPC	0.93	17.9	60
QPSK DVB-S2 LDPC	1/2	8.4	32.6
QPSK DVB-S2 LDPC	2/3	12.7	49.5
QPSK DVB-S2 LDPC	3/4	13.9	54
8PSK TCM	2/3	19.2	60
8PSK TCM RS	2/3	17.7	60
8PSK TPC	3/4	21.6	60
8PSK TPC	7/8	25.2	60
8PSK TPC	0.93	26.8	60
8PSK/8APSK DVB-S2 LDPC	2/3	19	60
8PSK/8APSK DVB-S2 LDPC	3/4	20.9	60
16QAM TPC	3/4	28.8	60
16QAM TPC	7/8	33.6	60
16QAM TPC	0.93	35.8	60
16QAM DVB-S2 LDPC	3/4	28	60
DVB-S2 QPSK	1/4	50	18.3
DVB-S2 QPSK	1/3	65.7	24.3
DVB-S2 QPSK	2/5	79	29.2
DVB-S2 QPSK	1/2	98.9	36.7
DVB-S2 QPSK	3/5	118.9	44.2
DVB-S2 QPSK	2/3	132.3	49.5
DVB-S2 QPSK	3/4	148.8	55.5
DVB-S2 QPSK	4/5	158.8	59.2
DVB-S2 QPSK	5/6	165.5	60
DVB-S2 QPSK	8/9	176.7	60
DVB-S2 QPSK	9/10	178.9	60
DVB-S2 8PSK	3/5	178	60
DVB-S2 8PSK	2/3	198.1	60
DVB-S2 8PSK	3/4	222.9	60
DVB-S2 8PSK	5/6	247.9	60
DVB-S2 8PSK	8/9	264.7	60
DVB-S2 8PSK	9/10	268	60
DVB-S2 16APSK	2/3	263.8	60
DVB-S2 16APSK	3/4	296.7	60
DVB-S2 16APSK	4/5	316.6	60
DVB-S2 16APSK	5/6	330.1	60
DVB-S2 16APSK	8/9	352.4	60
DVB-S2 16APSK	9/10	356.8	60

BER Performance - Guaranteed dB (Typical)												
DVB-S2 mode	Rate 1/4	Rate 1/3	Rate 2/5	Rate 1/2	Rate 3/5	Rate 2/3	Rate 3/4	Rate 4/5	Rate 5/6	Rate 8/9	Rate 9/10	
QPSK	5E-8	1.45 (1.1)	1.68 (1.33)	1.48 (1.13)	1.80 (1.45)	2.30 (1.95)	2.44 (2.09)	2.83 (2.48)	3.24 (2.89)	3.56 (3.21)	4.18 (3.83)	4.32 (3.97)
8PSK	5E-8				4.45 (4.10)	4.18 (3.83)	4.18 (3.83)	4.97 (4.62)	6.01 (5.66)	7.12 (6.77)	7.47 (7.12)	
16APSK	5E-8					5.94 (5.59)	5.94 (5.59)	6.53 (6.18)	7.25 (6.90)	7.16 (6.81)	8.48 (8.13)	8.93 (8.58)

Framing and Deframing Specifications	
Parameter	QUANTUM Series Modem
Closed Network Format	Unframed, no overhead.
IBS/SMS Option Format	Intelsat IBS to IESS-309 and IESS-310 up to 10 Mbps, and Eutelsat SMS to EESS-501.
IDR Option Format	Intelsat IDR to IESS-308 and IESS-310 up to 10 Mbps.
Closed Network plus ESC Format	Provides variable rate asynchronous ESC, optional synchronous scrambler above 32kbps to replace error multiplying V.35 scrambler, optional backward alarm facility and optional timeslot ID maintenance when used with Drop/Insert, all in minimum possible overhead down to <0.5%
Format of Other Modes	For custom options, see handbook.
Poor BER Performance	Deframer includes extended threshold operation that improves performance when used with Reed-Solomon in very poor BER conditions (where a single uncorrectable RS codeword can contain enough corrupt frame alignment words to knock an Intelsat scripted deframer out of frame sync). Up to 10 Mbps.

Clocking and Buffering Specifications		
Parameter	QUANTUM Series Modem	
Clock Integrity	Frequency Locked Loops give phase-hit immune operation even with poor clock sources such as routers etc.	
Tx Clocking SCPC mode	Internal	Standard (± 1 ppm)
	External	Tracking range ± 100 ppm/min
Rx Clocking SCPC mode	Rx Clock	Slaves Tx timing from Rx clock. (Includes full asymmetric operation)
	Buffer Disable	Clock from Satellite
	Tx Input clock	Plesiochronous. (Includes full asymmetric operation)
	Internal	Standard ± 1 ppm
	External timing clock (DTE interface only)	
	Station Reference (see below)	
Tx Clocking DVB-S2 mode	Internal	Free-running (tied to symbol rate)
	External	Tracking range ± 100 ppm/min
Rx Clocking DVB-S2 mode	Buffer Disable	Clock from Satellite
Station Reference Inputs	75 Ω BNC female Station Clock Connector, transformer isolated. 1MHz to 10MHz in 1kHz steps (accepts sinusoidal >0dBm or square-wave e.g. G.703 para 10)	
	120 Ω RS422 compatible input, 1MHz to 10MHz in 1kHz steps via Async ESC connector	
	NB: When set to 10MHz, the station reference may replace internal reference to all internal circuitry. Unit automatically switches back to internal reference if station reference fails.	
Buffer Size	Selectable in 1ms increments from 0ms to 99ms. Automatically adjusted to slip an integer number of terrestrial multi-frame lengths for framed rates. Buffer storage: Maximum buffer size – 256kbytes.	

Intelsat Reed-Solomon Codec & Custom Option Specifications	
Parameter	QUANTUM Series Modem
Maximum traffic rate	10Mbps
Format	Concatenated Reed-Solomon outer codec to IESS-308/310.
Code Rate	Default n, k, t = (126, 112, 7) depth 4. Automatically switches to: (225, 205, 10) depth 4 for 1544kbps IDR mode or (219, 201, 9) depth 4 for 2048kbps IDR mode and TCM \leq 1544kbps or (219, 201, 9) depth 8 for TCM > 1544kbps.
Processing Delay (bits)	Combined encoder and decoder: 8 x (2n-k+60) Combined Interleaver/De-Interleaver: 8 x n x Depth Calculate delay time using data rate including RS overhead.
Custom Option	When fitted allows arbitrary selection of n and k to provide fully variable code rate. $60 \leq n \leq 255$, $(n-20) \leq k \leq (n-2)$ in steps of 2. Interleaver depth of 4 or 8. The custom option allows use of shorter code words to reduce interleaver/de-interleaver delay on low data rate circuits.

Drop & Insert Option Specifications	
Parameter	QUANTUM Series Modem
Bearer Types	T1-D4, T1-ESF and E1-G.732
Timeslot Selection	Independent selection of arbitrary timeslots for both drop and insert.
Bearer Generation	The terrestrial bearer may be looped through the Drop Mux then Insert Mux, or terminated after the drop Mux and a new blank bearer generated by the insert Mux. The bearer generated within Insert Mux provides full multiframe and CRC support and may be generated from the Tx clock, station reference, satellite clock or internal reference.
Bearer Backup	In the event that Insert Mux bearer clock is lost, or AIS is supplied, then Insert Mux will switch temporarily to bearer generation mode in order to preserve receive traffic. The backup bearer may be generated from the station reference, satellite clock or internal reference.
Terrestrial CRC	Fully supported, with front panel display of terrestrial error rate based on CRC (T1-ESF and G.732) or Frame Alignment Word errors (all bearer types).
Timeslot ID	The IBS/SMS or Closed Net Plus ESC overhead maintains the identity of individual Drop/Insert timeslots for N=1,2,3,4,5,6,8,10,12,15,16, 20, 24 and 30. (See extended option below).

Extended Drop & Insert Option Specifications	
Parameter	QUANTUM Series Modem
Timeslot Re-Ordering	Selected timeslots may be independently re-ordered on both Tx and Rx paths.
Multi-Destination Working	All or only a subset of the received data may be inserted into the terrestrial bearer on the receive path for multi-destination working.
Timeslot ID Maintenance	The IBS/SMS or Closed Net Plus ESC is extended to maintain the identity of individual timeslots for all values of N from 1 to 31.
Signalling	Both Channel Associated Signalling (CAS) and Robbed Bit Signalling (RBS) are fully supported. For G.732 Drop/Insert, CAS signalling is extracted from terrestrial TS16 and carried over the satellite in IBS/SMS TS16 and TS48 before re-inserting into the distant terrestrial TS16. For RBS, the IBS or Closed Net Plus ESC overheads maintain the identity of the in-band signalling and it is re-inserted into the terrestrial multi-frame in the correct positions to maintain the RBS.

Advanced ESC and Advanced Aux Option Specifications		
Parameter	QUANTUM Series Modem	
ESC/Aux Port	A single port provides the interface for optional high rate async ESC (IBS/SMS option or Closed Net Plus ESC) or the Intelsat low rate async IBS ESC channel.	
Electrical Interface	RS232, RS422 or RS485 external interfaces or internal link to remote M&C port (software selected). Other devices externally wired in parallel with M&C port can also be accessed remotely.	
Async ESC Option	Closed Net Plus ESC	Overhead scales to provide any user specified async ESC baud rate whatever the satellite data rate. ESC limit is approximately 70% of main channel rate, overhead varies from <0.5% to >70%.
	IBS Option	High rate async data using from 1/32nd to 22/32nd of the IBS overhead, providing async baud rates from 0.2% to 5.1% of the terrestrial rate (e.g., up to >2400 baud at 64kbps). Includes modes compatible with the P300 and P400 Series, P230 & P1300/P1361 (using 20/32nd of the overhead).
IBS Aux Data Channel	With IBS option and Advanced Aux option: Intelsat low rate async ESC definition carried in bit 1 of TS32 providing a synchronous channel at 1/480th of the data rate, allowing up to one quarter of this rate for over-sampled async data. Compliant with Intelsat IESS-403 low rate ESC definition.	

Paired Carrier	
Parameter	QUANTUM Series Modem
Paired Carrier	Transmit and receive carriers are overlaid on top of each other in the same space segment. Echo cancellation techniques are used in the demodulator to cancel the transmit carrier and extract the wanted receive carrier signal.
Cancellation Bandwidth	Options available up to 2.5Msymbol/s, 5Msymbol/s and 10Msymbol/s.

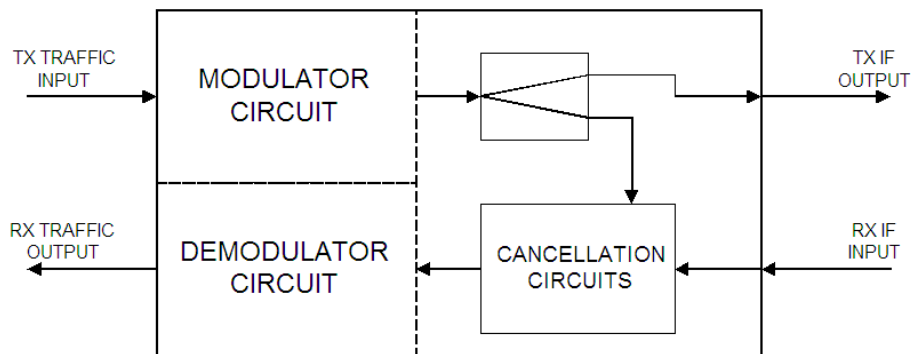

PAIRED CARRIER MODEM SCHEMATIC

Paired Carrier technology allows both the uplink and downlink signals to occupy the same space segment. An adaptive self-interference cancellation technique removes the uplink signal components generated by the local terminal from the received signal off satellite, allowing demodulation of the far end signal.

Ethernet Traffic	
Parameter	QUANTUM Series Modem
Standard (unaccelerated)	Base modem will pass UDP to at least 5Mbps (subject to prevailing data rate limits enabled in the modem) and unaccelerated TCP to typically 128kbps per connection, subject to an overall packet handling limit of 10,000 packets per second.
PEP (TCP/IP acceleration) Option	Performance Enhancing Protocol (acceleration) for TCP/IP traffic - overcomes performance problems associated with TCP over satellite. Maximum throughput on the base Modem 10Mbps.
Traffic mode	Bridging (standard) for point-to-point operation Brouting (Option) for point-to-multipoint and satellite outbound plus non-satellite return. Mesh network support. User selectable bridge between Ethernet traffic and Ethernet M&C port.
DHCP	Dynamic Host Control Protocol allows modem IP address to be allocated dynamically from an external DHCP network server.
Ethernet Header Compression	Compression of Ethernet frame headers at data rates up to 2Mbps. Typically reduces 14 byte Ethernet header to 1 byte.
IEEE 802.1p/q	IEEE 802.1p Quality of Service supporting the choice of strict priority queuing or fair weighting queuing. IEEE 802.1q VLAN support
IP Traffic card & options	Optional Encapsulation of IP packets and Ethernet frames over DVB uses Multi Protocol Encapsulation (MPE), Ultra Lightweight Encapsulation (ULE) or super efficient Paradise eXtreme Encapsulation (PXE) protocols. Supports TCP acceleration with maximum throughput rates of 20Mbps, subject to compatible options in the host modem. Supports up to 5,000 concurrent TCP connections. Overcomes the inherent limitations of standard TCP/IP over satellite. Improves the bandwidth utilisation to approximately 90% of selected data rate, with acceleration on. Reduces the inefficiencies of the standard TCP slow start algorithm. Prevents unnecessary activation of TCP congestion control algorithm. Optional Robust Header Compression to RFC 3095 profile 2 (IP/UDP). Typical reduction in header size for IP/UDP is from 28 bytes to between 1 & 3 bytes. 1-way packet handling limit of 29,000 packets per second. 2-way packet handling limit of 22,000 packets per second. Includes Ethernet header compression which typically reduces the 14 byte Ethernet header to 1 byte. Optional Dynamic Routing, supports RIP, OSPF and BGP, plus 64 static routes. Dual RJ45 ports support 10/100/1000 Base T Ethernet. Improves security by separating IP Traffic from Ethernet remote M&C on chassis. IP Traffic card includes HTTP Acceleration by prefetching webpage inline objects to reduce webpage download time. Can be operated in stand-alone, 1:1 or 1:N redundancy configuration.
Traffic Log Specifications	
Parameter	QUANTUM Series Modem
Capacity	Over 6000 entries
Entry Format	Fault message with time and date stamp. Separate entry when fault clears/changes.

Unique Web User Interface provides full Monitor & Control plus graphing of Eb/No, BER, Receive Power and other operating parameters, plus a Receive Spectrum Analyser, Receive Constellation Monitor and BER Tester for detailed signal analysis and performance validation via Internet Explorer. Logged graph data can be sent via email to any email address.

Built-in Spectrum Analyser for Receive Carrier, Adjacent Carrier and Super-Wide Monitoring (3 bandwidth settings).

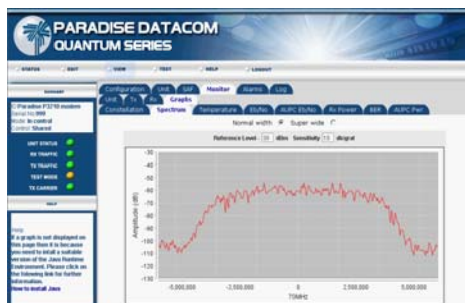

IDR Option Specifications	
Parameter	QUANTUM Series Modem
IDR ESC Audio	Two 32kbps ADPCM channels
Interface	4-wire 600Ω, +7dBm to -16dBm (programmable in 0.1dB steps).
Backward Alarms	Outputs: Four "form C" relays. Inputs: Four protected inputs, short to 0V to send alarm with matching summary Rx fail output. Alarm inputs software configurable for: a) All external patch, b) 1=Rx fail and 2-4=external patch, c) 1=Rx fail and 2-4=OK, d) 1-4=Rx fail
ESC/Aux Ports	When the IDR option is fitted, independent ESC & Aux ports on the IDR option replace the single shared ESC/Aux port on the base unit.
ESC Port	RS232, RS422 or RS485 external interfaces or internal link to remote M&C port (software selected). No external cabling required between the ESC and M&C ports for M&C via ESC channel within the overhead. Other devices externally wired in parallel with M&C port can also be accessed remotely. Provides clock, data and sync (ocet timing) lines.
IDR	Synchronous access to 8kbps IDR ESC. With the Async ESC option, async ESC access to the 8kbps IDR ESC is provided giving up to a 9600 baud async channel
	Others
Aux Port	RS232 or RS422 (user selectable). Provides clock and data lines.
IDR	Provides 32 or 64kbps access in place of one or both audio ESC channels.
	IBS

EZ BERT Option Specifications	
Parameter	QUANTUM Series Modem
BER Channel	The BERT may operate through main traffic, ESC or Aux data channels, or outputted via the terrestrial interface. Use of ESC & Aux data channels allows continuous real traffic BER performance monitoring whilst the modem carries traffic.
Test Patterns	PRBS 2 ^N -1: N=6, 7, 9, 11, 15, 19, 20, 23. All 1s, All 0s, Alternate Patterns, Sparse Patterns, QRSS, User. Compatible with common stand-alone BER testers.
Results	Display of error count and average BER.
Autolog	Automatic logging of average BER and other parameters at regular intervals.

BUC/LNB facilities	
Parameter	QUANTUM Series Modem
BUC Power Supply Options DC supplied via Tx IFL	Mains input, +48V DC 2A output (100W) Mains input, +24V DC 4A output (100W) Mains input, +48V DC 3.5A output (180W) Mains input, +24V DC 6A output (180W) +/-48V DC input, +48V DC 3.5A output (180W) +/-48V DC input, +24V DC 6A output (180W) +48V DC input, +48V DC 3.5A output (180W)
LNB Power (standard)	+15/24V 0.5A DC to LNB via Rx IFL - user configurable
FSK Control Option	Requires a BUC Power Supply to be fitted. Allows monitor & control of a compatible BUC from the Modem, via the Tx IFL.
10MHz Reference via IFL Option	10MHz may be provided via the Tx IFL to the BUC and via the Rx IFL to the LNB

Built-in Receive Constellation Display for channel diagnostics.

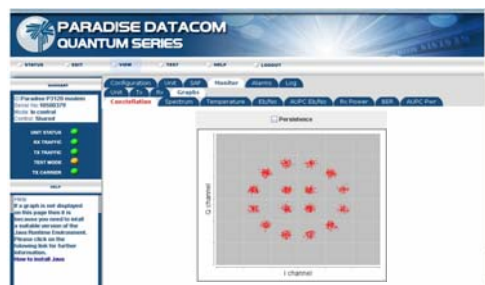

Common Specifications	
Parameter	QUANTUM Series Modem
Loop-backs	Interface Loop (Local and Remote) Framer Loop (Local) RS Loop (Local) FEC Loop (Local) Deframer/Framer Loop (Remote) Internal IF loopback (local, automatically matching Rx IF frequency to Tx)
Test Modes	Transmit CW (Pure Carrier) Transmit Alternate 1-0 Pattern Wideband spectrum analyzer display EZ Audio: 1kHz test tone on audio channels in IDR and P1348 emulation modes
Alarm Relays	4 Independent Change-Over Contacts: Unit Fault, Rx Traffic Fault Tx Traffic Fault, Deferred Alarm (backward alarm, BER or Eb/No below user set threshold)
Controller	Motorola PowerPC
Embedded Software	Revised embedded software may be downloaded into FLASH memory via Ethernet port with modem remaining in equipment rack.
Configuration Memories	>20 configurations can be stored and recalled from the front panel or remote M&C. Memories can be labelled with text string to aid identification.
User Interface	Clear and intuitive operator interface with plain English dialogue (other languages supported). Graphic display, backlight, high contrast, wide angle LCD. 17 key tactile full keyboard.
Remote Monitor And Control	For multi-drop applications, RS485 interface. For direct to PC applications, RS232 interface (front panel selectable). M&C port may be directly internally linked to ESC port for "over-the-satellite" M&C without cabling. Ethernet (10/100 BaseT) via RJ45, embedded Web server, SNMP agent V1, V2c and V3
Redundancy Features	1:1 redundancy controller built in. "Y" cables passively split data maintaining impedances. IF inputs/outputs are passively split, combined outside the units. Off-line unit tri-states data outputs and mutes Tx carrier.
Monitor	0-10V analogue output (Signal level, Eb/No, or Rx offset frequency) on Alarms & AGC connector.
Mechanical	1U chassis - 410mm deep, excluding front panel handles and rear panel connectors and fans.
Weight	3.5 kg
Power Supply	100-240VAC, +6%, -10%, 1A @ 100V, 0.5A @ 240V, 47-63Hz. Fused IEC connector (live and neutral fused). 48 Volts DC option
Safety	EN60950-1
EMC	EN55022 Class B (Emissions) EN55082 Part 1 (Immunity)
Environmental	Operating Temperature Range 0-50°C

AUPC Specifications	
Parameter	QUANTUM Series Modem
Modes of Operation	Monitor of distant Eb/No and BER only, full distant Eb/No maintenance. Unidirectional or Bi-directional operation.
Communication Link	Utilises asynchronous ESC channel on IBS/SMS, IDR and Closed Network plus ESC Carriers (ESC from 300 baud, i.e., overheads down to less than 1%). Maximum data rate 10 Mbps
User Parameters	Target Eb/No, positive power offset, negative power offset

Simple to use EZ-BERT BER Tester Option allows real time bit error measurements through traffic or ESC channel, or between the terrestrial ports.



PD60L DVBS2 L-band Satellite Modem

Fully configurable - only pay for what you need!

	Possible Modes		Description
	SCPC	DVB-S2	
PD60L L-band Base Modem	•	•	Wideband L-band: 950-1950 MHz in 100Hz steps, Closed Network modem, Closed Network plus ESC modem. Advanced ESC: Variable rate Async channel for Closed Net plus ESC operation. AUPC: Automatic Uplink Power Control (operates through ESC channel) Ethernet 10/100 BaseT on RJ45 for M&C. Remote Web Browser based monitoring tools (Spectrum Display, Constellation Monitor and link performance versus time) plus SMTP email client for status notification. DHCP allowing IP address to be allocated dynamically via external DHCP network server
	•	•	4.8kbps to 10Mbps, 1bps variable rate, BPSK/QPSK/OQPSK Includes Viterbi FEC, Rates 1/2, 3/4 & 7/8 with k=7. Intelsat Reed-Solomon Outer Codec to IESS 308. Unaccelerated Ethernet 10/100 Base T on RJ45 via traffic or overhead (Ethernet Bridging). Ethernet header compression at data rates up to 2Mbps. IEEE 802.1p QoS supporting choice of strict priority queuing or fair weighting queuing. IEEE 802.1q VLAN support.
	•	•	50kbps to 10Mbps, 1bps variable rate in DVB-S2 mode, requires a DVB-S2 option
Adds Data Rates to 16,896kbps	•	•	Extends base operation to 16,896kbps
Adds Data Rates to 25Mbps	•	•	Extends 16,896kbps operation to 25Mbps - requires 16,896kbps option
Adds Data Rates to 60Mbps	•	•	Extends 25Mbps operation to 60Mbps - requires 16,896kbps & 25Mbps options
Wideband L-band	•	•	Extends L-band coverage to 950-2050MHz in 100Hz steps
IP Acceleration on base Modem	•	•	TCP/IP Acceleration to 10Mbps on base Ethernet port, subject to prevailing data rate limits - overcomes performance problems associated with TCP over satellite
Ethernet Bridging	•	•	Ethernet Bridging for Point-to-Multipoint operation when there is a non-satellite return path - can be used with base Ethernet port or IP Traffic card
Position 1 (must choose 1 option) hardware option	•	•	EIA 530 D25 DCE providing selectable RS422 / X.21 / V.35 / RS232, also balanced G.703 if G.703 option fitted
	•	•	IDR operation to IESS 308. Two audio ESC channels, synchronous 8kbps ESC, four from 'C' backward alarms & Async access to 8k sync channel - includes EZ Audio test tone generator
	•	•	Blank Panel
Position 2 (must choose 1 option) hardware option	•	•	Serial LVDS on D25
	•	•	EIA 530 D25 DCE providing selectable RS422 / X.21 / V.35 / RS232, also balanced G.703 if G.703 option fitted
	•	•	HSSI on HD50 50-way SCSI-2 connector
	•	•	IP Traffic card providing TCP acceleration to 16,896kbps, subject to prevailing data rate limits, also provides HTTP Acceleration by prefetching webpage inline objects to reduce webpage download time - requires either Blank Panel or EIA 530 in position 1
	•	•	Eurocom D/1 on D25 male - pin compatible with P300 Eurocom
	•	•	Eurocom D/1 / EIA530 on D25 female
	•	•	Quad E1 Multiplexer with 1 x RJ45 port enabled plus integral G.703 and Drop & Insert included - requires IBS/SMS satellite framing
	•	•	Blank Panel
Position 2 Quad E1 Mux options - only used with Quad E1 Mux card	•	•	Adds Port 2 with Drop & Insert to Quad E1 card - requires Quad E1 Mux plus data rate option to 5Mbps
	•	•	Adds Port 3 with Drop & Insert to Quad E1 card - requires Quad E1 Mux with Port 2 option plus 5Mbps and 10Mbps data rate options
	•	•	Adds Port 4 with Drop & Insert to Quad E1 card - requires Quad E1 Mux with Port 2 option & Port 3 option plus 5Mbps and 10Mbps data rate options
	•	•	MultiMux - Allows base IP traffic and/or EIA530 traffic, if EIA530 interface fitted, to be used in place of 1 or 2 Quad E1 ports, each MultiMux port limited to 2,048kbps traffic rate
Position 2 IP Traffic card options	•	•	Adds TCP acceleration up to 25Mbps on IP Traffic card, subject to prevailing data rate limits - requires IP Traffic card
	•	•	Adds TCP acceleration up to 60Mbps on IP Traffic card, subject to prevailing data rate limits - requires IP Traffic card and requires 25Mbps Acceleration option
	•	•	Adds Robust Header Compression to RFC 3059 (IP/UDP) at throughput rates to 29kpkts/s (1-way), 22kpkts/s (2-way), subject to prevailing data rate limits - requires IP Traffic card
	•	•	Encapsulation of IP packets and Ethernet frames over DVB uses MPE or ULE protocols
	•	•	Adds Dynamic Routing: supports RIP, OSPF and BGP, plus 64 static routes - requires IP Traffic card
Position 3 (must choose 1) hardware option			No BNC traffic interface
			2 x BNC sockets providing unbalanced G.703 75 ohm - supplied only with G.703 option
DVB-S2 Modulation & Coding hardware options	•	•	DVB-S2 CCM Tx - includes QPSK, 8PSK & 16APSK for DVB-S2 use only, includes also LDPC/BCH Error Correction for DVB-S2 only. Must specify IP Traffic card if IP Traffic required
	•	•	DVB-S2 CCM Rx - includes QPSK, 8PSK & 16APSK for DVB-S2 use only, includes also LDPC-BCH Error Correction for DVB-S2 only. Must specify IP Traffic card if IP Traffic required
Low Rate TPC 2nd Generation Turbo 10Mbps maximum subject to prevailing data rate limits	•	•	Rates 5/16, 21/44, 0.493, 2/3, 3/4, 0.789, 7/8 Paradise (low latency) in BPSK, QPSK, OQPSK Rate 7/8 in QPSK, OQPSK Rate 0.93 Paradise in QPSK, OQPSK Rates 3/4, 7/8, 0.93 Paradise in 8PSK - requires 8PSK option Rates 3/4, 7/8, 0.93 Paradise in 16QAM - requires 16QAM option
High Rate TPC 2nd Generation Turbo All data rates to 20Mbps subject to prevailing data rate limits	•	•	Rates 5/16, 21/44, 0.493, 2/3, 3/4, 0.789, 7/8 Paradise (low latency) in BPSK, QPSK, OQPSK Rate 7/8 in QPSK, OQPSK Rate 0.93 Paradise in QPSK, OQPSK Rates 3/4, 7/8, 0.93 Paradise in 8PSK - requires 8PSK option Rates 3/4, 7/8, 0.93 Paradise in 16QAM - requires 16QAM option
Sequential FEC Limited to 2,048kbps maximum	•	•	Rates 1/2, 3/4, 7/8 in BPSK, QPSK, OQPSK
DVB-S2 LDPC to 5Mbps max	•	•	Low Density Parity Code (LDPC) plus Bose-Chaudhuri-Hocquenghem (BCH) error correction, short FECFRAME=16,200, 5Mbps maximum subject to prevailing data rate limits (hardware option) QPSK Rates 1/2, 2/3 & 3/4, 8PSK Rates 2/3 & 3/4 - requires 8PSK option, 8APSK Rates 2/3 & 3/4 - requires 8APSK option, 16QAM Rate 3/4 - requires 16QAM option
Adds DVB-S2 LDPC to 10Mbps	•	•	Extends DVB-S2 LDPC 5Mbps operation to 10Mbps - requires DVB-S2 LDPC to 5Mbps, and subject to prevailing data rate limits
Adds DVB-S2 LDPC to 20Mbps	•	•	Extends DVB-S2 LDPC 10Mbps operation to 20Mbps - requires DVB-S2 LDPC to 5Mbps and DVB-S2 LDPC to 10Mbps, and subject to prevailing data rate limits
8APSK	•	•	8APSK - requires DVB-S2 LDPC FEC option
8PSK Including TCM	•	•	Rate 2/3 8PSK Pragmatic TCM to IESS 310 8PSK Turbo available - requires 2nd Generation Turbo FEC option
16QAM	•	•	16QAM - requires either 2nd Generation Turbo FEC option or DVB-S2 LDPC option
IBS / SMS	•	•	Satellite Framing to IESS 309 with low rate Intelsat ESC (to IESS 403) & High Rate IBS/SMS ESC
Audio Channels	•	•	P1348 Emulation mode for IBS 64kbps carrier (2xaudio) or 128kbps (2xaudio + 64kbps data) - requires IBS / SMS & IDR options
Drop / Insert including Extended D/I	•	•	T1/E1 linear order Drop/Insert, plus independent timeslot re-ordering on Tx & Rx. Signalling (E1 CAS & T1 RBS). Rx Partial Insert for multi-destinational working, Timeslot ID maintenance for N=1 to 31 with IBS / SMS or Closed Net plus ESC. Drop/Insert can operate with any interface, although G.703 is typically used (requires G.703 option if used in G.703 mode)
Advanced AUX	•	•	Variable rate synchronous Aux channel for IBS / SMS - requires IBS / SMS option IDR 32/64kbps in place of one/both audio ADPCM ESC channels - requires IDR option
Custom	•	•	Custom RS Outer Codec values of n, k and interleaver depth. Custom IBS / SMS modes, allocation of overhead between ESC and Aux channels in IBS / SMS, custom backward alarms in IBS / SMS, and Closed Net plus ESC - requires IBS/SMS option. Custom IDR mode - requires IDR option.
EZ BERT - PRBS Tester	•	•	Internal Bit Error Rate Tester (BERT) can run through main data channel, or ESC/Aux channels, or output/input via the terrestrial interface
OM-73	•	•	OM-73 Scrambling, symbol mapping and Viterbi compatibility
Paired Carrier	•	•	Paired Carrier Multiple Access - allows the overlay of outgoing and incoming satellite signals
24V 100W BUC PSU	•	•	P3542 AC Input, 24V 100W DC to Tx BUC (hardware option)
48V 100W BUC PSU	•	•	P3541 AC Input, 48V 100W DC to Tx BUC (hardware option)
24V 180W BUC PSU	•	•	P3544 AC Input, 24V 180W DC to Tx BUC (hardware option)
48V 180W BUC PSU	•	•	P3543 AC Input, 48V 180W DC to Tx BUC (hardware option)
48V DC Input	•	•	Floating 48V DC Primary power input in place of 100-240V AC input (hardware option)
48V in & 24V BUC PSU	•	•	P3546 Floating 48V DC Input with P3538 +24V 180W DC to Tx BUC (hardware option)
48V in & 48V BUC PSU	•	•	P3545 Floating 48V DC Input with P3537 +48V 180W DC to Tx BUC (hardware option)
+48V in & 48V BUC PSU	•	•	P3547 48V DC Primary power input in place of 100-240V AC input (hardware option)
FSK Control Option	•	•	Controls and monitors single-box Paradise Datacom BUC from the modem (hardware option)
Adaptive Signal Predistorter	•	•	Use with 16QAM to relax HPA backoff by up to 1.6dB. Compensates for HPA non-linearities in ground segment and/or transponder. Requires 16QAM option.
Tx Only operation	•	•	Transmit functions only
Rx Only operation	•	•	Receive functions only

Paradise Datacom reserves the right to change specifications of products described in this document at any time without notice and without obligation to notify any person of such changes.