



μBUC X-Band or Ku-Band Block Up Converter

Description

Paradise Datacom's μBUC is a Block Up Converter available in X and Ku -Band. The module is designed specifically for highly mobile commercial and military satellite communication applications. The μBUC is ideal for use in any Fly-away or Manpack application where miniature form factor and light weight are a requirement.

The converter locks to a 10 MHz external reference signal of -10 dBm to +5 dBm. The external reference must be diplexed on the L-Band Input Connector.

The unit requires a customer designed heatsink.

FEATURES

- Ku-Band Output:
10, 20 and 25 W
- X-Band Output:
10 and 20 W
- Multiple reference
frequency operation
- L-Band Input
- Miniature and light
weight
- Ideal for fly-away and
manpack applications

Ku-Band Specifications

PARAMETER	NOTES	LIMITS	UNITS
Input Frequency	Option 950-1700	950 - 1450	MHz
Output Frequency	Option 13.75-14.50	14.0 - 14.5	GHz
LO Frequency	At 14.0-14.5 GHz	13.05	GHz
	At 13.75-14.50 GHz	12.80	GHz
Gain		50	dB
Gain Flatness	full band	± 2.0	dB
Gain Slope	per 40 MHz	± 0.25	dB
Gain variation vs. Temperature	-30 to +60 °C baseplate	0 ± 2.0	dB
Output Power		P_{sat} / P_{1dB}	
	10W	40.5 / 40.0	dBm
	20W	43.0 / 42.0	dBm
	25W	44.0 / 43.0	dBm
Intermodulation Distortion	3dB back off relative to P_{1dB}	-25	dBc
Spurious	In-Band Signal Related	-60	dBc
	Close to Carrier Spurious (≤ 20 MHz)	-60	dBc
	Local Oscillator	-50	dBm
	Non-Signal Related	-60	dBm
Harmonics	2 nd harmonic measured at P_{1dB}	-40	dBc
Output Spectrum	Low side Local Oscillator	Non Inverted	
Input Return Loss		12	dB
Output Return Loss		12	dB
Noise Figure		15	dB
Group Delay (per 40 MHz segment)	Linear	0.01	ns/MHz
	Parabolic	0.003	ns/MHz ²
	Ripple	1.0	ns p-p
Reference Input Frequency	Diplexed on L-Band Input Connector	10	MHz
Reference Input Power	Diplexed on L-Band Input Connector	-10 to +5	dBm
Input Voltage	+48 VDC nominal	+36 to +60	VDC
	+24 VDC nominal	+24 ±10%	VDC
	+12 VDC nominal	-12 ±10%	VDC
Input Power	10W @ 48 VDC	130	W
	10W @ 24 VDC	150	W
	20W @ 48 VDC	200	W
	20W @ 24 VDC	220	W
	25W @ 48 VDC	230	W
	25W @ 24 VDC	250	W
Monitor & Control Functions	Tx Inhibit (GND for Unmute) Temperature Fault Summary Fault		
Alarm Output	Open Collector Output (requires external pull-up)	Open = Fault	
Weight Dimensions	L x W x H	4.5 (2.0) 7.98 x 4.0 x 2.25 (203.2 x 101.6 x 57.1)	lb. (kg) in (mm)
Heatsink (must meet thermal resistance specification)	10W µBUC	0.230	°C/W
	20W µBUC	0.150	°C/W
	25W µBUC	0.125	°C/W

Specifications are subject to change.

X-Band Specifications

PARAMETER	NOTES	LIMITS	UNITS
Input Frequency		950 - 1450	MHz
Output Frequency		7.90 - 8.40	GHz
LO Frequency		6.95	GHz
Gain		60	dB
Gain Flatness	full band	± 2.0	dB
Gain Slope	per 40 MHz	± 0.25	dB
Gain variation vs. Temperature	-40 to +60 °C baseplate	0 ± 2.0	dB
Output Power	10W 20W	P_{sat} / P_{1dB} 40.5 / 40.0 43.5 / 43.0	dBm dBm
Intermodulation Distortion	3dB back off relative to P_{1dB}	-25	dBc
Spurious	In-Band Signal Related Close to Carrier Spurious (≤ 20 MHz) Local Oscillator Non-Signal Related	-60 -60 -50 -60	dBc dBc dBm dBm
Harmonics	2 nd harmonic measured at P_{1dB}	-40	dBc
Output Spectrum	Low side Local Oscillator	Non Inverted	
Input Return Loss		12	dB
Output Return Loss		12	dB
Noise Figure		15	dB
Group Delay (per 40 MHz segment)	Linear Parabolic Ripple	0.01 0.003 1.0	ns/MHz ns/MHz ² ns p-p
Reference Input Frequency	Diplexed on L-Band Input Connector	10	MHz
Reference Input Power	Diplexed on L-Band Input Connector	-10 to +5	dBm
Input Voltage	+48 VDC nominal +24 VDC nominal +12 VDC nominal	+36 to +60 +24 ±10% -12 ±10%	VDC VDC VDC
Input Power	10W @ 48 VDC 10W @ 24 VDC 20W @ 48 VDC 20W @ 24 VDC	95 110 110 130	W W W W
Monitor & Control Functions	Tx Inhibit (GND for Unmute) Temperature Fault Summary Fault		
Alarm Output	Open Collector Output (requires external pull-up)	Open = Fault	
Weight Dimensions	L x W x H	4.5 (2.0) 7.98 x 4.0 x 2.25 (203.2 x 101.6 x 57.1)	lb. (kg) in (mm)
Heatsink (must meet thermal resistance specification)	10W μBUC 20W μBUC 25W μBUC	0.230 0.150 0.125	°C/W °C/W °C/W

Specifications are subject to change.

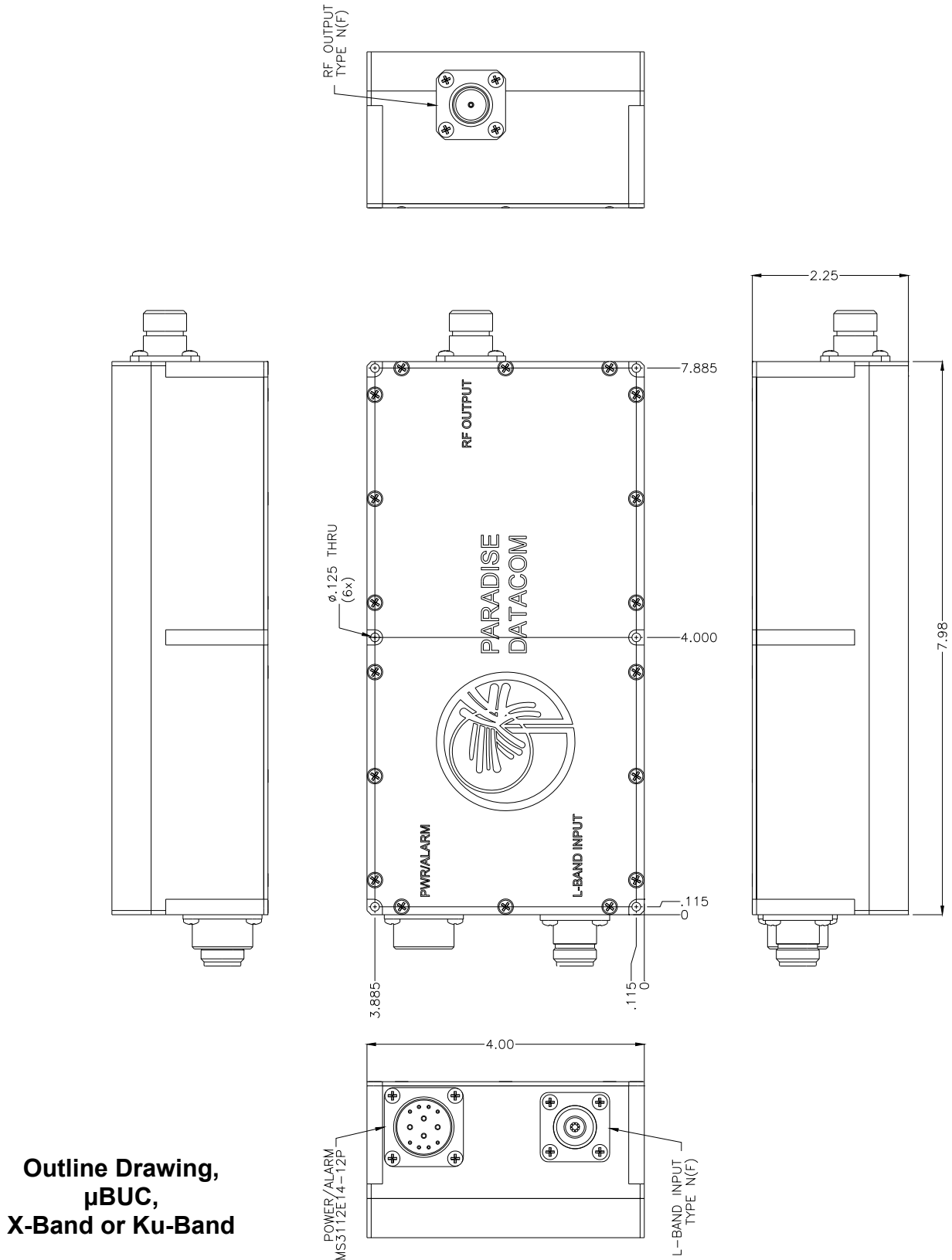

**Outline Drawing,
μBUC,
X-Band or Ku-Band**

Local Oscillator Phase Noise

Offset	Guaranteed Max.	X-Band or Ku-Band (Typical)	Units
10 Hz	-30	-60	dBc/Hz
100 Hz	-60	-75	dBc/Hz
1 KHz	-70	-75	dBc/Hz
10 KHz	-80	-100	dBc/Hz
100 KHz	-90	-110	dBc/Hz
1 MHz	-90	-122	dBc/Hz

Part Number Configuration

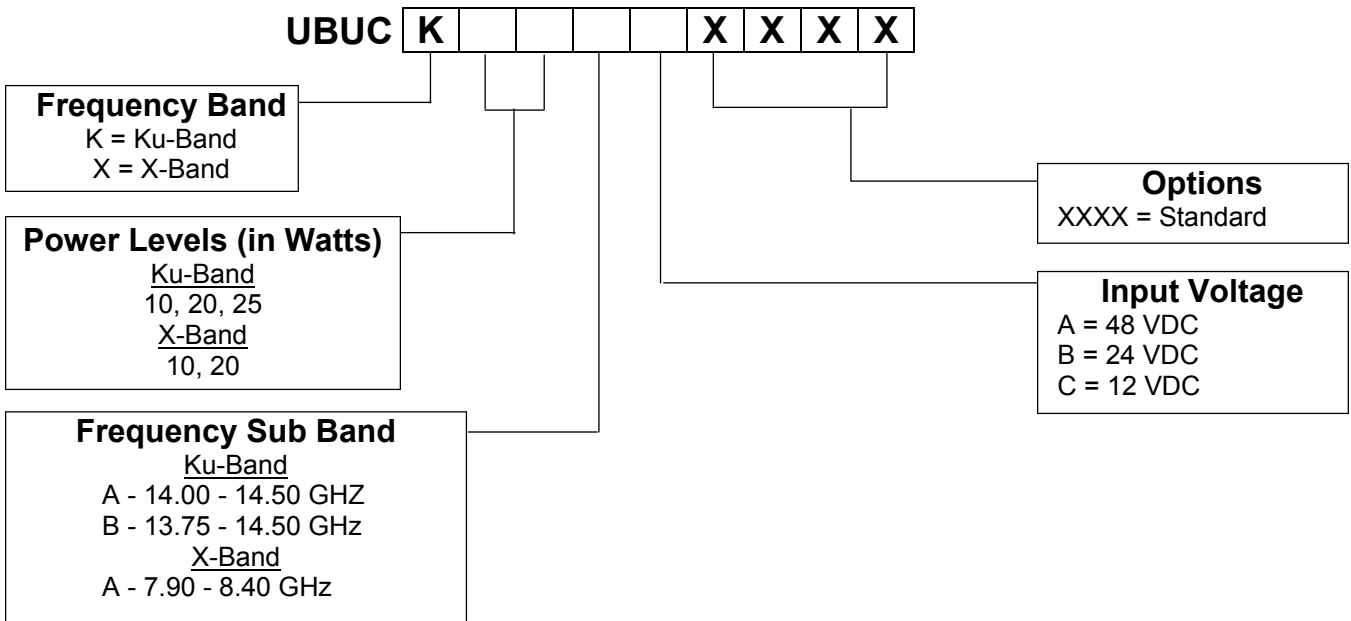

Specifications are subject to change without notice.