



## Ku-BAND TRANSCEIVER 100W TO 150 W L-BAND INTERFACE AWMT-5000KL® series



### FEATURES

- Operating Ku-Band Tx: 14.00 - 14.50 GHz  
13.75 - 14.50 GHz (optional)  
Rx: 10.95 - 12.75 GHz (sub-bands)
- L band Tx and Rx interface
- Easy to install and operate
- Compact light weight design
- Weatherproof package
- Phase-locked LNB
- Low phase noise
- Remote Monitor & Control (RS-232/RS-485)
- Relay alarm indicators
- LED status indicators
- Automatic high reflected power protection
- Harmonic Filter
- High stability internal 10MHz reference
- Downloadable PC GUI
- Redundant ready operation

### OPTIONS

- Extended Ku-band (13.75 – 14.50 GHz )
- LNA operation
- Remote M&C panel (Ethernet port optional)
- External 10 MHz reference with auto sensing

### OVERVIEW

The Advantech range of transceivers uses the latest technology, thus providing the ultimate in performance and user friendly operation at a very competitive price.

AWMT-5000KL® is a family of hub-mount transceivers operating in the Ku-band from 100W to 150 W. These transceivers are designed for continuous operation in the harshest outdoor environment. The built-in microprocessor controller provides for external monitoring and control of the operating parameters, and for the redundancy control. The LNB is connected to the transceiver with a single coaxial cable. Apart from the LNB, the complete unit is available in a single integrated package. Higher power transceivers are also available in the AWMT-KL® series for up to 150W.

The flexible and comprehensive monitor and control features on the transceiver ensure that it will fit into any network management system architecture. The user-friendly RS-232 interface will provide full set-up and fault monitoring facilities via a PC terminal mode communication or a hand-held terminal. The RS-485 interface will provide functional remote Monitor & Control, using the Graphic User Interface (GUI) or the Monitor & Control Panel.

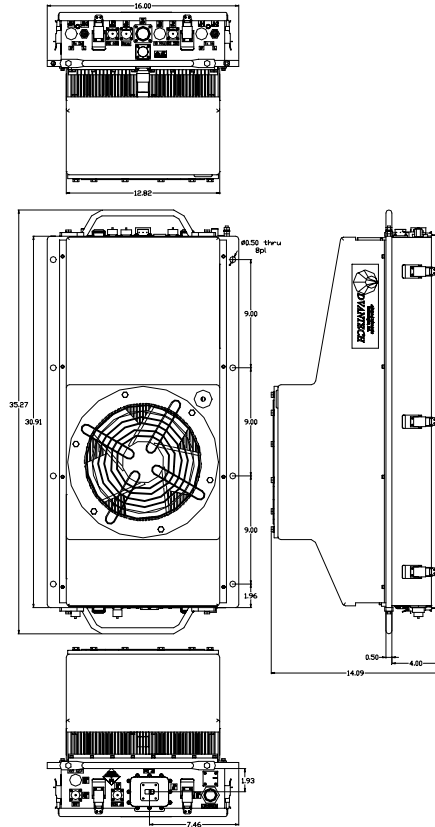

### APPLICATION

The AWMT-5000KL® is designed to operate in the Ku-band with L-band interface. The unit is self-contained and is intended for mounting outdoors, close to the OMT of an antenna.

### REDUNDANCY

The AWMT-5000KL® series of transceivers may be configured to operate in 1:1 redundancy mode. No extra controller is required for redundancy operation, as the built-in controller in each amplifier provides this function. Redundancy kits are required for redundant operation.

### ACCESSORIES

- Mounting kits for transceiver installation
- Redundancy kits
- Mounting frame for redundancy applications
- Transmit Reject Filter and/or Receive Reject Filter (external)
- Remote Control Panel
- Hand-Held terminal

Transceivers RTX AWMT Series



**Ku-BAND TRANSCEIVER 100 W TO 150 W**  
**L-BAND INTERFACE**  
**AWMT-5000KL® series**



<b>Transmit Path</b>			
Model	100W	125W	150W
P1dB min. (dBm)	+49	+50	+51
Gain min @ max. gain set (dB)	69	70	71
Power Consumption	1000W	1200W	1400W

Unit Weight	50 Kg (110lbs)
Dimensions (L x W x H)	35.27" x 16.00" x 14.09" (85.59 x 40.64 x 35.79 cm)

<b>Transmit Path</b>			
<b>L-Band Input</b>		<b>RF Output</b>	
Frequency range	950-1450 MHz	Frequency range	14.00 – 14.50 GHz
Input Connector	Type N female	(Non-inverting)	13.75 – 14.50 GHz (optional)
Input Return Loss	18 dB / 50 Ω	Output connector	WR 75
<b>Gain Specification</b>		Output Return Loss	20 dB (18 dB for coaxial output)
Gain control range	20 dB (0.1 dB step size)	Third order IMD (2 tones 5 MHz apart)	-25 dBc max at 3dB total back-off from rated P1dB
Gain flatness	3.0 dB p-p	Spurious	-55 dBc max at rated power
Gain stability	3.0 dB p-p max over temp. range	Noise Power Density	-70 dBm/Hz max in TX band -145 dBm/Hz max in 10.95 – 12.75 GHz in RX band

<b>Receive Path</b>			
<b>RF Input</b>		<b>Gain Specification</b>	
RF Input Frequency	10.95 – 12.75 GHz	Gain (LNB + Receiver)	80 dB @ max gain set
	* Field selectable bands	Gain control range	20 dB (0.1 dB step size)
Bands	1) 10.95 – 11.70 GHz 2) 11.70-12.20 GHz 3) 12.25-12.75 GHz	Gain flatness	±2.5 dB max over full RF band
RF Input Interface	WR75	Gain stability	±3.0 dB max over temp. range
Input VSWR	2.5:1	Spurious	-55 dBc max
<b>L-Band Output</b>		Image Rejection	50 dB
Frequency range	950 – 1450 MHz 950 – 1700 MHz (optional)	<b>LNB Parameters</b>	
Output P1dB, min	+10 dBm	LNB type	Phase locked to 10 MHz ref. (from Transceiver via coax. cable)
Output Connector	Type N female / 50 Ω	Noise Temperature	65°K
Output Return Loss	18 dB/50 Ω	L-band Output Frequency	950-1750 MHz
		L-band Output Interface	Type N female 50 Ω
		Conversion Gain	60 dB
		DC power	12±18V DC (via coaxial cable)
		<b>LNA Parameters(optional)</b>	
		Noise Temperature	85°K
		Output Interface	Type N female 50 Ω
		Gain	60 dB
		DC Power	12±18V DC (via coaxial cable)

<b>Common Parameters (Tx &amp; Rx)</b>			
<b>Synthesizer step size</b>	1 MHz (option 125 KHz)	<b>Environmental</b>	
<b>Frequency Stability</b>		Cooling	Forced Air
-40°C to +55°C	±2 x 10 <sup>-8</sup>	Operational	-30°C to +55°C standard (-40°C to +55°C option)
Aging	±1 x 10 <sup>-7</sup> /year	Storage	-55°C to +85°C
<b>Phase Noise</b>	(With internal 10MHz reference)	Humidity	Up to 100% condensing
Offset frequency	Phase noise (max)	Altitude	3,000 m AMSL (derated 2°C/300m)
100 Hz	-63 dBc/Hz	<b>Power Requirements</b>	
1000 Hz	-73 dBc/Hz	AC input voltage	220 VAC (47-63 Hz)
10 KHz	-83 dBc/Hz	AC Connector	MS3102R20-19P
100 KHz	-93 dBc/Hz	<b>Mechanical</b>	
<b>Monitor &amp; Control</b>		Dimensions	See Table above
Serial port (RS-485)	MS3112E10-6P	Packaging	Weatherproof for outdoor use
Serial port (RS-232)	MS3112E10-6P		
Redundancy Port	MS3112E16-26P		
Discrete Port	MS3112E12-10P		

PB-WTL330-01 Rev.02 issued on 04/23/2007 Specifications are subject to change without notice

CE An ISO9001: 2000 Company



**SATCOM SERVICES**  
 Mike Termondt  
 25 Creek Lane  
 Oak View, CA 93022 USA  
 Tel.: (805) 649-1284  
 Fax: (805) 500-4328  
 Email: Mike@satcom-services.com

