



FEATURES

- 70 or 140 MHz Tx and Rx interface
- Easy to install and operate
- Compact light weight design
- Weatherproof package
- Phase-locked LNB
- Low phase noise
- Remote Monitor & Control (RS-232 and RS-485)
- Relay alarm indicators
- LED status indicators
- Automatic high reflected power protection
- Harmonic Filter
- High stability internal 10MHz reference
- Downloadable PC GUI
- Redundant operation ready

OPTIONS

- Extended C-Band (5.85 – 6.725 GHz)
- Additional L band interface
- LNA operation
- Step Size 125 KHz option
- Remote M&C panel (Ethernet port optional)
- External 10 MHz reference with auto sensing

OVERVIEW

The Advantech range of transceivers uses the latest technology, local and remote control thus providing the ultimate in performance and user friendly operation at a very competitive price.

AWMT-5000C® is a family of hub-mount transceivers operating in the C-band from 250W to 500W. These transceivers are designed for continuous operation in the harshest outdoor environment. The built-in microprocessor controller provides for external monitoring and control of the operating parameters, and for the redundancy control. The LNB is connected to the transceiver with a single coaxial cable. Apart from the LNB, the complete unit is available in a single integrated package. Higher power transceivers are also available in the AWMT-C® series for up to 500W.

The flexible and comprehensive monitor and control features on the transceiver ensure that it will fit into any network management system architecture. The user-friendly RS-232 interface will provide full set-up and fault monitoring facilities via a PC terminal mode communication or a hand-held terminal. The RS-485 interface will provide functional remote

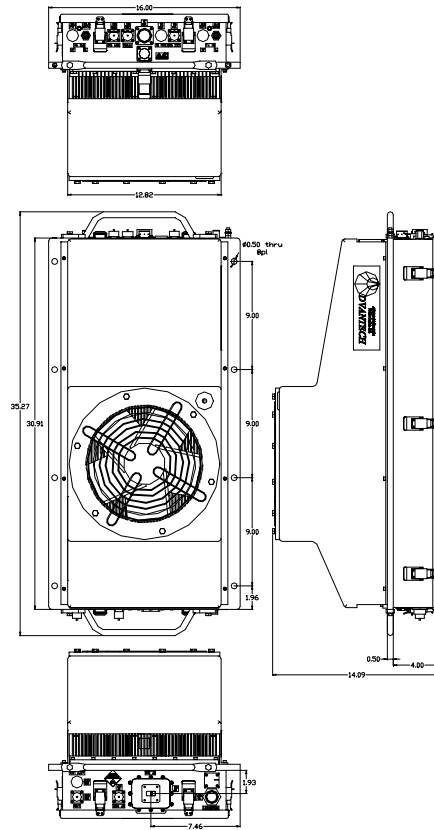

Monitor & Control, using the Graphic User Interface (GUI) or the Monitor & Control Panel.

APPLICATION

The AWMT-5000C® is designed to operate in the C-band with 70 MHz or 140 MHz IF interface. The unit is self-contained and is intended for mounting outdoors, close to the OMT of an antenna.

REDUNDANCY

The AWMT-5000C® series of transceivers may be configured to operate in 1:1 redundancy mode. No extra controller is required for redundancy operation, as the built-in controller in each amplifier provides this function. Redundancy kits are required for redundant operation.

ACCESSORIES

- Mounting kits for transceiver installation
- Redundancy kits
- Mounting frame for redundancy applications
- Transmit Reject Filter and/or Receive Reject Filter (external)
- Remote Control Panel
- Hand-Held terminal



C-BAND TRANSCEIVER 250 W TO 500 W AWMT-5000C® series



Transmit Path				
Model	250W	300W	400W	500W
P1dB min. (dBm)	53	54	55	56
Gain min @ max. gain set (dB)	74	75	76	77
Power Consumption	1800	2000	2400	3000

Unit Weight	50 kg (110lbs)	60 kg (132lbs)
Dimensions (L x W x H)	35.27" x 16.00" x 14.09" (85.59 x 40.64 x 35.79 cm)	

Transmit Path			
IF Input		RF Output	
Frequency range	70 ± 18 MHz (140 ± 36 MHz optional)	Frequency range (Non-inverting)	5.850 – 6.425 GHz 6.425 – 6.725 GHz 6.725 – 7.025 GHz
Input Connector	Type N female	Output connector	CPR 137G (N-Type option up to 150 W)
Input Return Loss	18dB / 50 Ω	Output Return Loss	20 dB (18 dB for coaxial cable)
		Third order IMD (2 tones 5 MHz apart)	-26 dBc max at 3dB total back-off from rated P1dB
		Spurious (in band)	-55 dBc max
		Noise Power Density	-70 dBm/Hz max in TX band -155 dBm/Hz in max 3.4 – 4.2 GHz in RX band
Gain Specification			
Gain control range	20 dB (0.1 dB step size)		
Gain flatness	3.0 dB p-p max over 36 MHz		
Gain stability	3.0 dB p-p max over temp. range		

Receive Path			
RF Input		Gain Specification	
RF Input Frequency	3.625 – 4.2 GHz 3.400 – 3.700 GHz (CP) 4.5 – 4.8 GHz (CI)	Gain (LNB + Receiver)	80 dB @ max gain set
RF Input Interface	CPR-229G	Gain control range	20 dB (0.1 dB step size)
Input VSWR	2.5:1	Gain flatness	±3.0 dB max over full RF band
		Gain stability	3.0 dB p-p max over temp. range
		Spurious	-55 dBc
		Image Rejection	50 dB
IF Output		LNB Parameters	
Frequency range	70 ± 18 MHz (140 ± 36 MHz optional)	LNB type	Phase lock to 10 MHz ref. (from Transceiver via coax. cable)
Output Level	+5 dBm	Noise Temperature	35°K
Output Connector	Type N female / 50 Ω	L-band Output Frequency	950-1750 MHz
Output Return Loss	18 dB/50 Ω	L-band Output Interface	Type N female 50 Ω
		Conversion Gain	60 dB
		DC power	12±18V DC (via coaxial cable)
		LNA Parameters (optional)	
		Noise Temperature	35°K (30°K optional)
		Output Interface	Type N female 50 Ω
		Gain	60 dB
		DC power	12±18V DC (via coaxial cable)

Common Parameters (Tx & Rx)			
Synthesizer step size	1 MHz (option 125 KHz)		
Frequency Stability	-40°C to +55°C ±2 x 10 ⁻⁸		
Aging	±1 x 10 ⁻⁷ /year		
Phase Noise	(With internal 10MHz reference)		
Offset frequency	Phase noise (max)		
100 Hz	-60 dBc/Hz	-65 dBc/Hz typical	
1000 Hz	-70 dBc/Hz	-73 dBc/Hz typical	
10 KHz	-80 dBc/Hz	-85 dBc/Hz typical	
100 KHz	-90 dBc/Hz	-95 dBc/Hz typical	
Monitor & Control			
Serial port (RS-485)	MS3112E10-6P		
Serial port (RS-232)	MS3112E10-6P		
Redundancy Port	MS3112E16-26P		
Discrete Port	MS3112E12-10P		
Environmental			
Cooling	Forced Air		
Operational	-30°C to +55°C standard (-40°C to +55°C option)		
Storage	-55°C to +85°C		
Humidity	Up to 100% condensing		
Altitude	3,000 m AMSL (derated 2°C/300m)		
Power Requirements			
AC input voltage	220 VAC (47-63 Hz)		
AC Connector	MS3102R20-19P		
Mechanical			
Packaging	Weatherproof for outdoor use		

PB-WT130-01 Rev.03 issued on 08/29/2007 Specifications are subject to change without notice



An ISO9001: 2000 Company



SATCOM SERVICES

Mike Termond
25 Creek Lane
Oak View, CA 93022 USA
Tel.: (805) 649-1284
Fax: (805) 500-4328
Email: Mike@satcom-services.com

